



NED University of Engineering & Technology
Department of Electrical Engineering

LAB MANUAL
For the course

EE-127 CIRCUIT ANALYSIS

Instructor name: _____

Student name: _____

Roll no: _____ **Batch:** _____

Semester: _____ **Year:** _____

LAB MANUAL

For the course

EE-127 CIRCUIT ANALYSIS

Content Revision Team:

Dr. Abdurrahman Javid Shaikh, Shariq Shaikh

Approved By

The Board of Studies of Department of Electrical Engineering

Summary of Rubric Sheets for Data Entry in OBE MIS System [to be entered as they are on OBE portal with no scaling]

Lab #	Extent of achievement	Lab #	Extent of achievement	Lab #	Extent of achievement
Total out of 32		Total out of 32		Total out of 32	

Lab #	Extent of achievement	Lab #	Extent of achievement	Lab #	Extent of achievement
Total out of 32		Total out of 32		Total out of 32	

Add six total scores from above to get total Rubric score Out of 192	R=
Scaled to 25 marks (R/192)*25	S=
Lab Attendance percentage from portal:	A=
Attendance scaled to 5 marks: (A/100)*5	P=
For entry on NED exam portal Total lab sessionals out of 30: S + P	T=

PBL/OEL	Extent of achievement	Final	Extent of achievement
Total out of 32		Total out of 32	

Add two total scores from above to get total final Rubric Score Out of 64	Z=
For entry on NED exam portal Total Final Lab Marks scaled to 20 marks (Z/64)*20	F=

CONTENTS

S.No.	Date	Title of Experiment	Total Marks	Signature
1		To study the operation of: 1. Oscilloscope as a measuring instrument & 2. Function Generator as an Input Source		
2		To investigate the Transient Response of First order RC Circuit.		
3		To investigate the Transient Response of First order RL Circuit.		
4		Investigating Resonance phenomena in RLC circuits & experimentally determines the resonance frequency in a series RLC circuit.		
5		To understand the importance of test/switching functions. Design and test the performance of integrator circuits using Op-amp.		
6		To understand the importance of test/switching functions. Design and test the performance of differentiator circuits using Op-amp.		
7		To investigate the behavior of Over Damping, Critical Damping & Under Damping in RLC Circuit		
8		Use MATLAB to analyze types of power and RMS and peak values of current and voltages		
9		Use MATLAB and Simulink to plot waveforms of instantaneous voltage, current & Power for R, L& C and mixed & Load. OPEN ENDED LAB		
10		To measure the Three Phase Power of Star connected load using Three Wattmeter methods.		

11		To measure the Three Phase Power of Delta connected load using Two Wattmeter methods		
12		To determine the turns ratio of a transformer, also determine the polarity of transformer windings for their parallel operation		
13		To investigate ABCD Transmission Parameters for Two Port Network.		
14		PBL: Simulation of 3 phase wye and delta connected loads		

Lab Session 01

OBJECT:

To study the operation of oscilloscope as a measuring instrument & function generator as an Input Source.

EQUIPMENT REQUIRED:

1. Oscilloscope [GW Instek GDS-820S]
2. Function Generator [GFG-8020H (2MHz)]
3. Probes

THEROTICAL DESCRIPTION:

OSCILLOSCOPE:

The main purpose of an oscilloscope is to **graph an electrical signal as it varies over time**. Most scopes produce a two-dimensional graph with **time on the x-axis and voltage on the y-axis**.

DIGITAL STORAGE OSCILLOSCOPE:

A digital storage oscilloscope (often abbreviated DSO) is an oscilloscope which stores and analyses the signal digitally rather than using analog techniques.

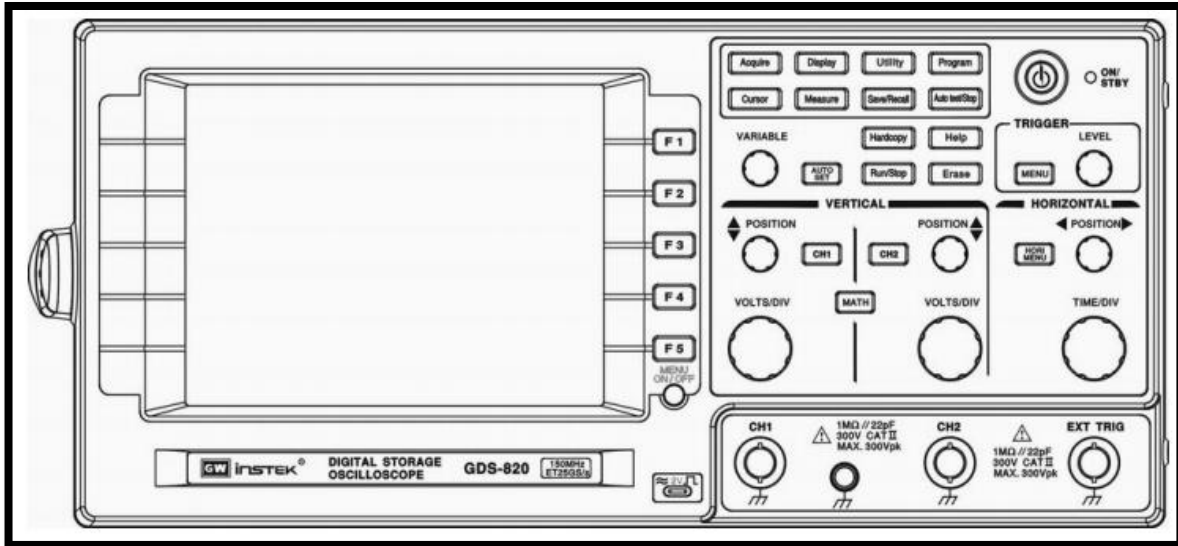

Fig1.1 Front Panel View of Oscilloscope

- **First Time Operation:**

1. **Testing the Probe (Calibration Process):**







Probes are single-input devices that route a signal from your circuit to the scope. They have a sharp **tip** which probes into a point on your circuit. The tip can also be equipped with hooks, tweezers or clips to make latching onto a circuit easier. Every probe also includes a **ground clip**, which should be secured safely to a common ground point on the circuit under test.

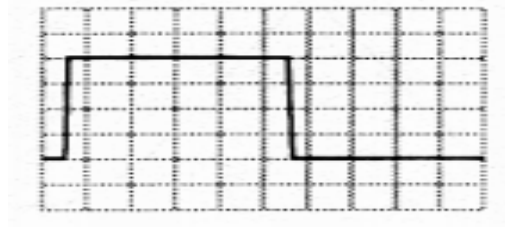

Fig1.2 Probes Terminal Connections

As soon as you connect positive part of the probe to the signal output terminal the square wave will display on the scope screen. The magnitude and frequency of displayed square wave are 2Vp-p and 1 KHz respectively. Now when both positive & negative parts of probes are connected with hook terminal the positive waveform will be grounded.



Coupling  /  /  : Press **F1** softkey to select **AC** (), **DC** () coupling, or ground ().

Invert On/Off: Press **F2** softkey to select to turn (waveform) invert on or off

Bw Limit On/Off: Press **F3** softkey to switch between 20MHz or full bandwidth.

Probe 1/10/100: Press **F4** softkey to select the probe's $\times 1$, $\times 10$, or $\times 100$ attenuation.

Impedance $1M\Omega$: Input impedance display. Always $1M\Omega$ input impedance for GDS-800 series digital storage oscilloscope.

Fig1.3 Square Wave As a result of Calibration Process

2. AUTOSET:

The "Autoset" function provides a stable display of any input signal (almost) and set the parameters to default settings.

- **Vertical controls:**

Channel 1, 2 Position knobs: The position control knobs adjust the vertical position of the channel 1 and channel 2 waveforms, **CH1, CH2 Menu pushbutton**: Shows the vertical waveform function and waveform display on/off, **VOLTS/DIV knobs**: Adjusts the vertical scale of the waveforms.

- **Horizontal controls:**

Horizontal Menu: **Horizontal POSITION knob**: Adjust waveforms horizontal position, **TIME/DIV knob**: Adjusts the horizontal scale of selected waveform.

- **Basic Settings of Both Channels:**

- **Miscellaneous Controls:**

1. **MEASURE:**

This oscilloscope provides various automatic measurements. Automatic measurements are taken over the entire waveform record, or the area specified by cursors. Select the different measurement by pressing F1 to F5 key. To activate the measurement press the Measure button. The measurement parameters for both channels displayed are:

V_{pp}, V_{amp}, V_{avg}, V_{rms}, V_{hi}, V_{lo}, V_{max}, V_{min}, Freq, Period, Width, Duty Cycle, Rise time and Fall time.

2. **CURSOR:**

It is convenient to be able to make measurements of the signal being displayed on the oscilloscope. To activate the cursors press the Cursor button. The cursors, which appear as vertical or horizontal lines will be displayed.

- The vertical cursor lines define the measurement with respect to change in Voltage ΔV .
- The horizontal cursor lines define the measurement with respect to change in Time Δt .

FUNCTION GENERATOR:

A *function generator* is usually a piece of electronic test equipment or software used to generate different types of electrical waveforms over a wide range of frequencies. Some of the most common waveforms produced by the *function generator* are the sine wave, square wave, triangular wave and sawtooth shapes.

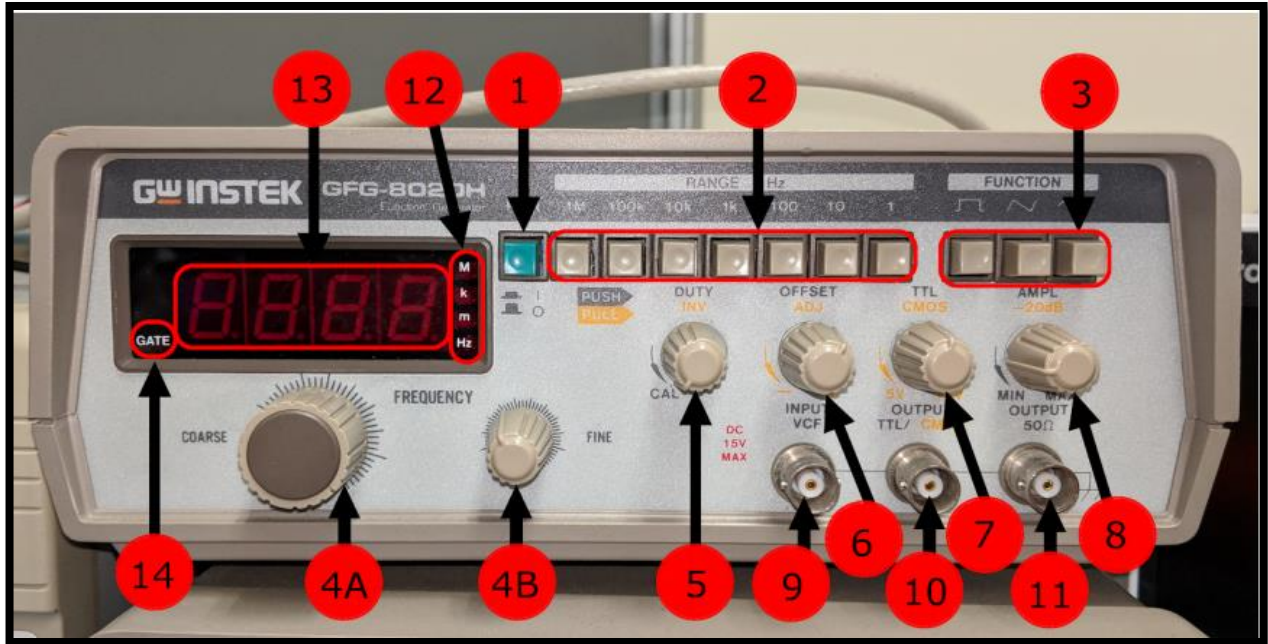

Fig1.4 Function Generator Front Panel

1. **Power Switch:** The power switch turns the device on or off.
2. **Range Selectors:** This bank of switches is used to select the frequency range of the output signal.
3. **Function Selectors:** This bank of switches is used to select the desired output function type (Square, Triangle, and Sine).
4. **Frequency Adjustment Knob COARSE:** This knob adjusts the output frequency of the waveform over a wide range, but with less precision than the Fine Frequency Adjustment Knob.
Frequency Adjustment Knob FINE: This knob adjusts the output frequency of the waveform over a narrower range, but with more precision than the Coarse Frequency Adjustment Knob.
5. **DUTY:** This knob position should be counter clockwise (for 50% Duty Cycle). The Duty function varies the duty Cycle from 50% to 100%.
6. **OFFSET/ADJ Knob:** This knob position should be counter clockwise in order to disabled this function.
8. **AMPL:** Increase or Decrease the magnitude of selected waveform.
11. **OUTPUT 50Ω:** The 50Ω Output is the generic waveform output; it is the source of all of the waveforms other than TTL and CMOS. 50Ω is the internal resistance of this output circuit and should be accounted for when using this device.

PROCEDURE:

- Firstly perform the calibration of Oscilloscope and Check all the probes as well.
- Use Channel CH1 to observe the waveforms.
- Connect one probe to (CH1) of oscilloscope and other probe to the function generator terminal (OUTPUT50Ω).
- Now connect the positive-positive terminals of both probes with each other and negative-negative terminals with each other in order to the view the output of function generator on oscilloscope.

- Oscilloscope Settings: CH1, Coupling to AC, Probe $\times 1$, Impedance $1M\Omega$, Invert OFF, Bandwidth Limit OFF.
- Function Generation Settings: DUTY knob (CCW, Pulled in), OFFSET knob (CCW, Pulled in), obtain the desired waveform of any frequency, amplitude and shape.
- Using oscilloscope's MEASURE function, observe VRMS, VPP, FREQUENCY, TIME PERIOD & DUTY CYCLE
-

OBSERVATIONS:

S.No	Waveshape	V _{rms} (V)		V _{p-p} (V)		Frequency (Hz)	Time Period (msec)
		calculated	measured	calculated	measured	measured	measured
1.							
2.							
3.							

CALCULATIONS:

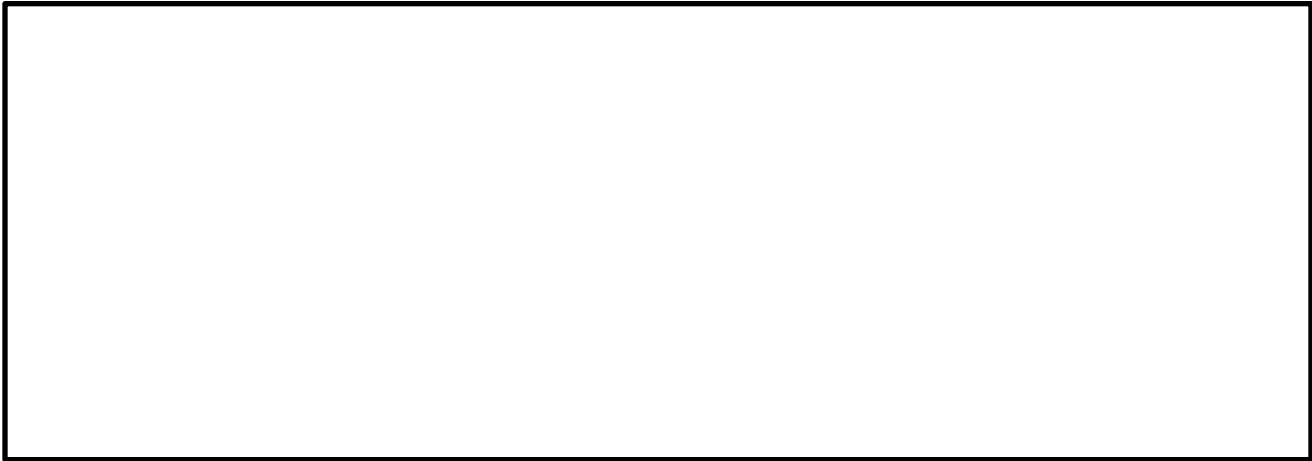

Answer the following:

Q-1) What does AC, DC and GND coupling do on an oscilloscope?

Q-2) What is the OFFSET option in function generator?

Q-3) What is Duty Cycle?

Lab Session 02

OBJECT:

To investigate the Transient Response of First order RC Circuit.

EQUIPMENT REQUIRED:

1. Oscilloscope
2. Function Generator
3. Probes
4. Breadboard
5. Resistor- $1k\Omega(1)$, Capacitor- $1\mu f(1)$

THEROTICAL DESCRIPTION:

The Transient Response of RC & RL Circuit:

The Transient Response of circuit also known as the Natural Response is the way the circuit responds to energies stored in storage elements, such as capacitors and inductors. If a capacitor and inductor has energy stored within it, then that energy can be dissipated or absorbed by a resistor. How that energy is dissipated is the Transient Response. The RC & RL circuit leads to 1st order differential equation to solve the circuit if the circuit contains only one storage element.

RC Circuit:

When switch is closed at position **1** (step input is applied to circuit), Capacitor voltage begins at zero and exponentially increases to E volts and capacitor current instantaneously jumps to E/R and exponentially decays to zero. (**Charging Phase**)

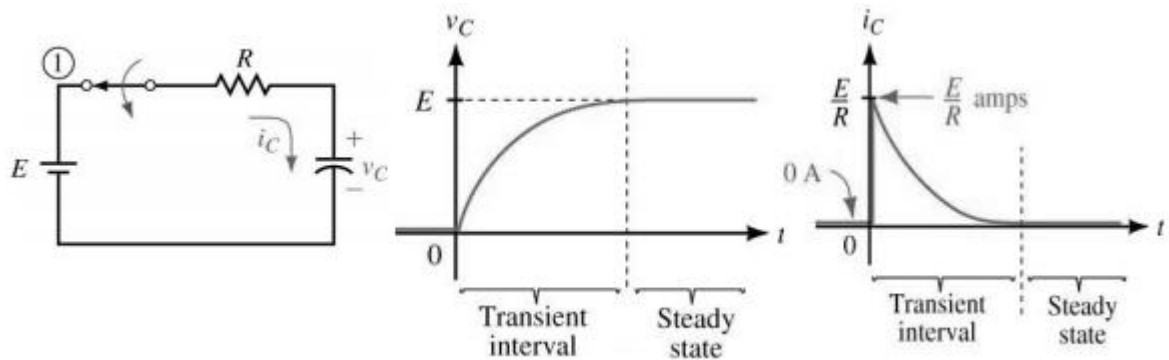

Fig 2.1: RC Circuit Charging State

When switch is closed at position 2, Capacitor voltage has E volts across it when it begins to discharge and capacitor current will instantly jump to $-E/R$. Both voltage and current will decay exponentially to zero. (**Discharging Phase**)

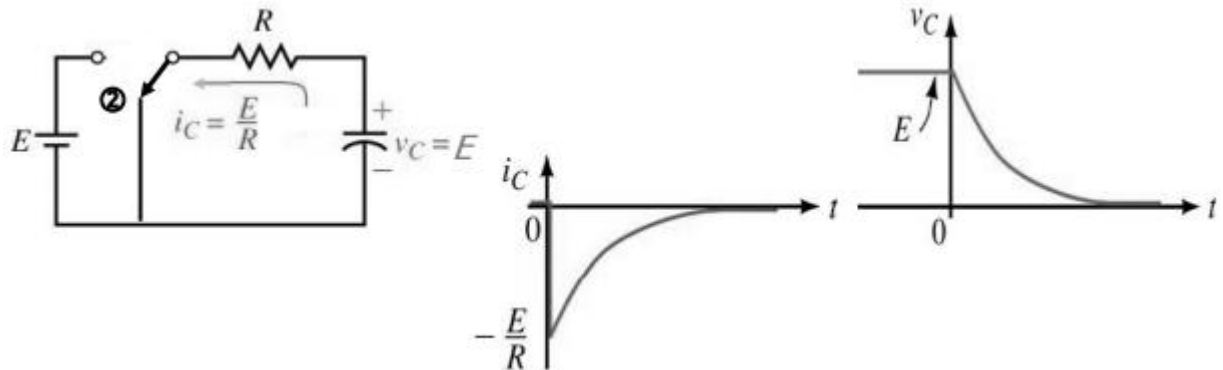

Fig 2.2: RC Circuit Discharging State

Capacitor Charging Equations:

$$v_C = E (1 - e^{-t/RC})$$

$$i_C = \frac{E}{R} e^{-t/RC}$$

$$v_R = E e^{-t/RC}$$

Capacitor Discharging Equations:

$$v_C = V_0 e^{-t/\tau}$$

$$v_R = -V_0 e^{-t/\tau}$$

$$i_C = -\frac{V_0}{R} e^{-t/\tau}$$

Where τ is defined as: Rate at which a capacitor charges depends on product of R and C and known as time constant, $\tau = RC$ has units of seconds. Length of time that a transient lasts depends on exponential function $e^{-t/T}$, for all practical purposes, transients can be considered to last for only five time constants.

CIRCUIT DIAGRAM:

For RC Circuit:

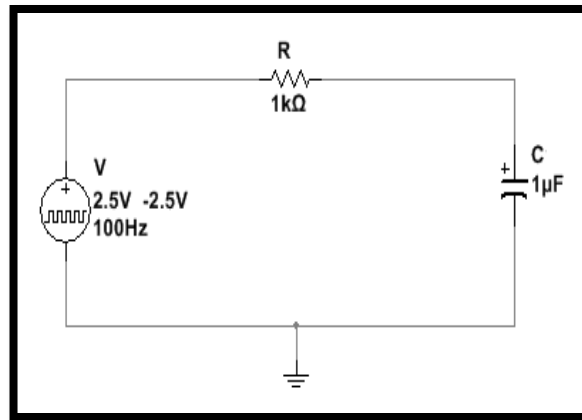

PROCEDURE:

- Assemble circuit on breadboard.
- Apply input signal to circuit from function generator.
- The amplitude of Input signal is 5Vp-p, 50% duty cycle. Set frequency to 100Hz (for RC).
- Connect Channel 1 to Input and Channel 2 across output to observe waveforms.
- Use Scope's CURSOR option to obtain Δt & ΔV readings for different values of τ .
- Note down measured values and compare with calculated data.
- Sketch waveforms on graph paper.

OBSERVATIONS:

For RC Circuit:

case	ΔV_c (V)	Δt (sec)	5τ (sec)	τ (sec)

Charging				
Discharging				

Plot/pictures of the waveforms:

Answer the following:

Q-1) What is the difference between step response, transient response and steady state response?

Q-2) Name any one application for both RC based Circuit?

Q-3) What will happen if the polarity of capacitor is reversed in the circuit?

Q-4) Can you replace polarized capacitor with non-polarized one? If, yes then why?



Course Code and Title: _____

Laboratory Session: No. _____ Date: _____

Psychomotor Domain Assessment Rubric-Level P3					
Skill Sets	Extent of Achievement				
	0	1	2	3	4
Equipment Identification Sensory skill to identify equipment and/or its component for a lab work.	Not able to identify the equipment.	--	--	--	Able to identify equipment as well as its components.
Equipment Use Sensory skills to describe the use of the equipment for the lab work.	Never describes the use of equipment.	Rarely able to describe the use of equipment.	Occasionally describe the use of equipment.	Often able to describe the use of equipment.	Frequently able to describe the use of equipment.
Procedural Skills Displays skills to act upon sequence of steps in lab work.	Not able to either learn or perform lab work procedure.	Able to slightly understand lab work procedure and perform lab work.	Able to somewhat understand lab work procedure and perform lab work.	Able to moderately understand lab work procedure and perform lab work.	Able to fully understand lab work procedure and perform lab work.
Response Ability to imitate the lab work on his/her own.	Not able to imitate the lab work.	Able to slightly imitate the lab work.	Able to somewhat imitate the lab work.	Able to moderately imitate the lab work.	Able to fully imitate the lab work.
Observation's Use Displays skills to perform related mathematical calculations using the observations from lab work.	Not able to use lab work observations into mathematical calculations.	Able to slightly use lab work observations into mathematical calculations.	Able to somewhat use lab work observations into mathematical calculations.	Able to moderately use lab work observations into mathematical calculations.	Able to fully use lab work observations into mathematical calculations.
Safety Adherence Adherence to safety procedures.	Doesn't adhere to safety procedures.	Slightly adheres to safety procedures.	Somewhat adheres to safety procedures.	Moderately adheres to safety procedures.	Fully adheres to safety procedures.
Equipment Handling Equipment care during the use.	Doesn't handle equipment with required care.	Rarely handles equipment with required care.	Occasionally handles equipment with required care.	Often handles equipment with required care.	Handles equipment with required care.
Group Work Contributes in a group-based lab work.	Never participates.	Rarely participates.	Occasionally participates and contributes.	Often participates and contributes.	Frequently participates and contributes.

Lab Session 03

OBJECT:

To investigate the Transient Response of First order RL Circuit.

EQUIPMENT REQUIRED:

1. Oscilloscope
2. Function Generator
3. Probes
4. Breadboard
5. Resistor-1k Ω (1), Inductor-1mh(1)

THEROTICAL DESCRIPTION:

The Transient Response of RC & RL Circuit:

The Transient Response of circuit also known as the Natural Response is the way the circuit responds to energies stored in storage elements, such as capacitors and inductors. If a capacitor and inductor has energy stored within it, then that energy can be dissipated or absorbed by a resistor. How that energy is dissipated is the Transient Response. The RC & RL circuit leads to 1st order differential equation to solve the circuit if the circuit contains only one storage element.

RL Circuit:

Current $i(t)$ in an RL circuit is an exponentially increasing function of time. When switch is closed at position **1** (step input is applied to circuit), current begins at zero and rises to a maximum value, voltage across resistor V_R is an exponentially increasing function of time and voltage across inductor V_L is an exponentially decreasing function of time. (**Charging Phase**)

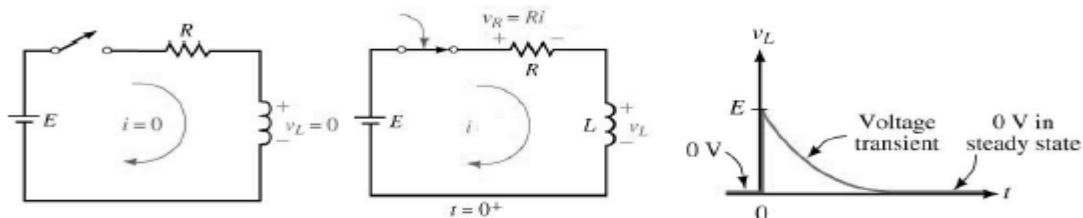
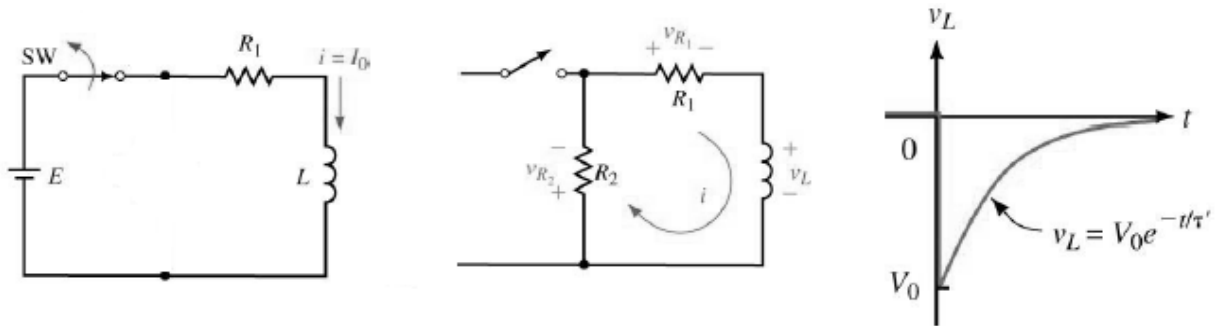

Fig 3.1: RL Circuit Charging State

When switch is now again in open condition inductor discharges by changing polarity across terminals the R2 serves as discharge path switch, inductor voltage has $-(V_0)$ volts across it when it begins to discharge and inductor current will instantly jump to V_0/R . Both voltage and current will decay exponentially to zero. (**Discharging Phase**)



3.2: RL Circuit Discharging State

Fig

Inductor Charging Equations:

$$i(t) = \frac{E}{R} (1 - e^{-Rt/L})$$

$$v_R = E \left(1 - e^{-\frac{Rt}{L}} \right)$$

$$v_L = E \cdot e^{-Rt/L}$$

Inductor Discharging Equations:

$$i = I_0 e^{-t/\tau}$$

$$v_L = V_0 e^{-t/\tau}$$

$$v_R = R \cdot I_0 e^{-t/\tau}$$

Where τ is defined as: Rate at which an inductor charges depends on ratio of R and L and known as time constant, $\tau = L/R$ has units of seconds. Length of time that a transient lasts depends on exponential function $e^{-t/T}$.

CIRCUIT DIAGRAM:

For RL Circuit:

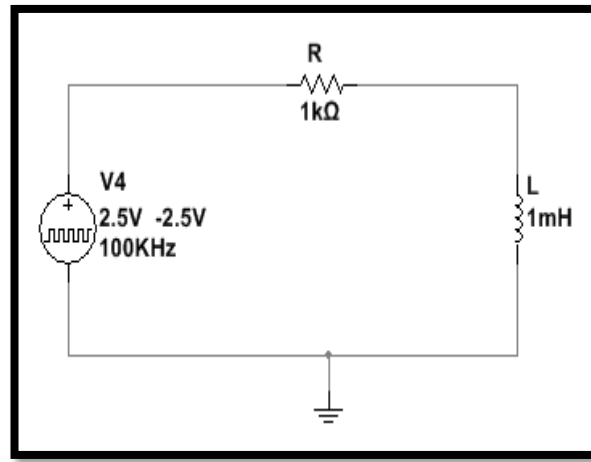

PROCEDURE:

- Assemble circuit on breadboard.
- Apply input signal to circuit from function generator.
- The amplitude of Input signal is 5Vp-p, 50% duty cycle. Set frequency to 100kHz (for RL).
- Connect Channel 1 to Input and Channel 2 across output to observe waveforms.
- Use Scope's CURSOR option to obtain Δt & ΔV readings for different values of τ .
- Note down measured values and compare with calculated data.
- Sketch waveforms on graph paper.

OBSERVATIONS:

For RL Circuit:

case	ΔV_c (V)	Δt (sec)	5τ (sec)	τ (sec)
Charging				
Discharging				

CALCULATIONS:

Q-1) What is the difference between step response, transient response and steady state response?

Q-2) Name any one application for RL based Circuit?

Q-3) A coil which has an inductance of 40mH and a resistance of 2Ω is connected together to form a LR series circuit. If they are connected to a 20V DC supply.

- a) What will be the final steady state value of the current?
- b) What will be the time constant of the RL series circuit.
- c) What will be the transient time of the RL series circuit?
- d) What will be the value of the induced emf after 10ms?
- e) What will be the value of the circuit current one time constant after the switch is closed.



Course Code and Title: _____

Laboratory Session: No. _____ Date: _____

Psychomotor Domain Assessment Rubric-Level P3					
Skill Sets	Extent of Achievement				
	0	1	2	3	4
Equipment Identification Sensory skill to identify equipment and/or its component for a lab work.	Not able to identify the equipment.	--	--	--	Able to identify equipment as well as its components.
Equipment Use Sensory skills to describe the use of the equipment for the lab work.	Never describes the use of equipment.	Rarely able to describe the use of equipment.	Occasionally describe the use of equipment.	Often able to describe the use of equipment.	Frequently able to describe the use of equipment.
Procedural Skills Displays skills to act upon sequence of steps in lab work.	Not able to either learn or perform lab work procedure.	Able to slightly understand lab work procedure and perform lab work.	Able to somewhat understand lab work procedure and perform lab work.	Able to moderately understand lab work procedure and perform lab work.	Able to fully understand lab work procedure and perform lab work.
Response Ability to imitate the lab work on his/her own.	Not able to imitate the lab work.	Able to slightly imitate the lab work.	Able to somewhat imitate the lab work.	Able to moderately imitate the lab work.	Able to fully imitate the lab work.
Observation's Use Displays skills to perform related mathematical calculations using the observations from lab work.	Not able to use lab work observations into mathematical calculations.	Able to slightly use lab work observations into mathematical calculations.	Able to somewhat use lab work observations into mathematical calculations.	Able to moderately use lab work observations into mathematical calculations.	Able to fully use lab work observations into mathematical calculations.
Safety Adherence Adherence to safety procedures.	Doesn't adhere to safety procedures.	Slightly adheres to safety procedures.	Somewhat adheres to safety procedures.	Moderately adheres to safety procedures.	Fully adheres to safety procedures.
Equipment Handling Equipment care during the use.	Doesn't handle equipment with required care.	Rarely handles equipment with required care.	Occasionally handles equipment with required care.	Often handles equipment with required care.	Handles equipment with required care.
Group Work Contributes in a group-based lab work.	Never participates.	Rarely participates.	Occasionally participates and contributes.	Often participates and contributes.	Frequently participates and contributes.

Lab Session 04

OBJECT:

Investigating Resonance phenomena in RLC circuits & experimentally determines the resonance frequency in a series RLC circuit.

EQUIPMENT REQUIRED:

1. Oscilloscope
2. Function Generator
3. Probes
4. Breadboard
5. Resistor-470 Ω (1), Inductor-10mh(1), Capacitor-10nf(1)

THEROTICAL DESCRIPTION:

A series resonant circuit consists of a resistor, a capacitor, and an inductor in a simple loop. At some frequency the capacitive and inductive reactances will be of the same magnitude, and as they are 180 degrees in opposition, they effectively nullify each other. This leaves the circuit purely resistive, the source “seeing” only the resistive element. Consequently, the current will be at a maximum at the resonant frequency. At any higher or lower frequency, a net reactance (the difference between X_L and X_C) must be added to the resistor value, producing higher impedance and thus, a lower current. As this is a simple series loop, the resistor’s voltage will be proportional to the current. Consequently, the resistor voltage should be a maximum at the resonant frequency and decrease as the frequency is either increased or decreased.

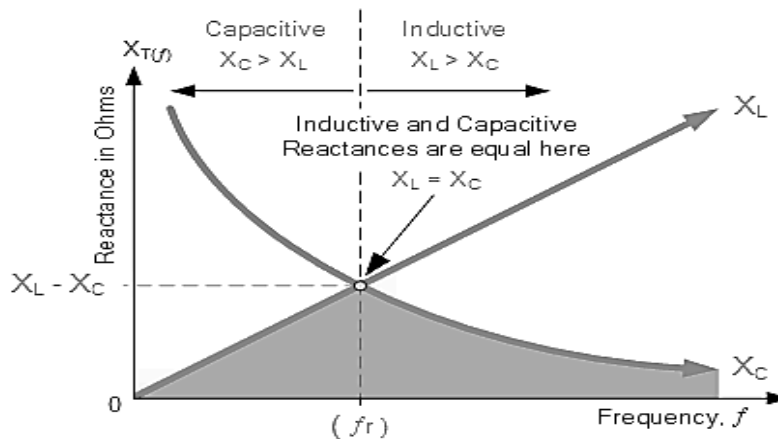

Fig 4.1: Series Resonance

At resonance, the resistor value sets the maximal current and consequently has a major effect on the voltages developed across the capacitor and inductor as well as the “tightness” of the voltage versus

frequency curve: The smaller the resistance, the tighter the curve and the higher the voltage seen across the capacitor and inductor. The Q of the circuit can be defined as the ratio of the resonant reactance to the circuit resistance, $Q=X/R$, which also corresponds to the ratio of the resonant frequency to the circuit bandwidth, $Q=f_r/BW$.

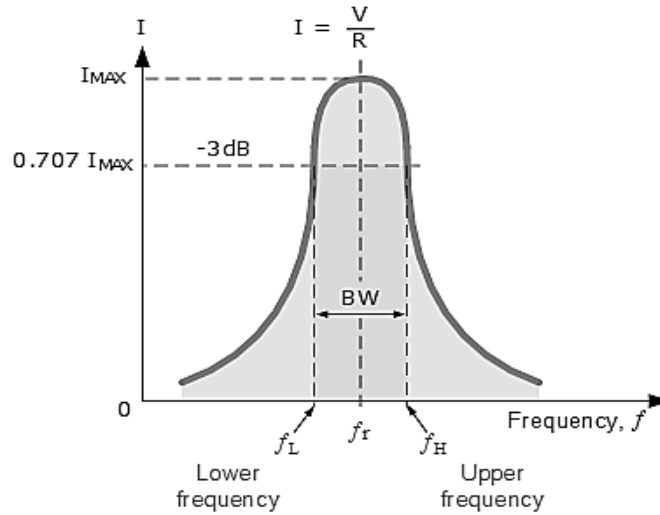
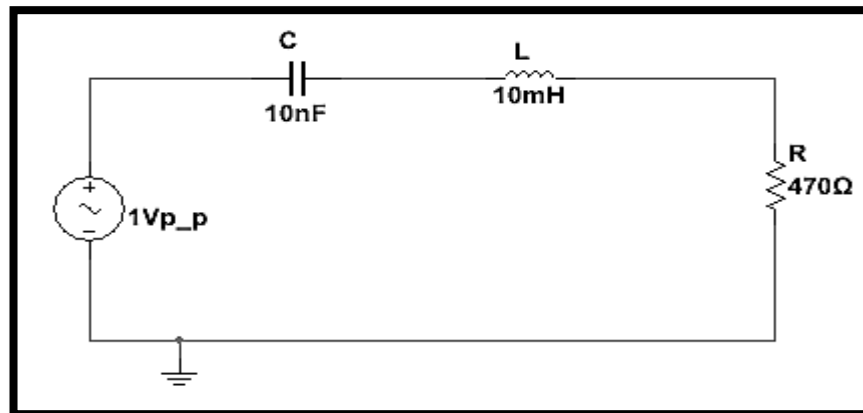

Fig 4.2: Bandwidth of a Series Resonance

CIRCUIT DIAGRAM:



PROCEDURE:

- Using circuit diagram with $R=470\Omega$, $L= 10 \text{ mH}$, and $C=10 \text{ nF}$, determine the theoretical resonance frequency and Q, and record the results in first observation Table. Based on these values determine the upper and lower frequencies defining the bandwidth, f_1 and f_2 , and record them in Table.
- Build the circuit using $R=470\Omega$, $L=10 \text{ mH}$ and $C=10 \text{ nF}$. Place a probe across the resistor. Set the output of the generator to a 1 V p-p sine wave. Set the frequency to the theoretical resonance frequency of first observation Table.

- Adjust the frequency in small amounts, up and down, until the maximum voltage is found. This is the experimental resonance frequency. Record it in Table. Note the amplitude (it should be approximately equal to the source voltage of 1 V p-p). Sweep the frequency above and below the resonance frequency until the experimental f_1 and f_2 are found. These will occur at voltage amplitude of approximately 0.707 times the resonant voltage (i.e., the half-power points). Record these frequencies in Table. Also, determine and record the experimental Q based on the experimental f_0 , f_1 , and f_2 .
- Also measure and record the inductor and capacitor voltages. Note that the inductor and capacitor will have to be swapped with the resistor position in order to maintain proper ground reference with the oscilloscope.

OBSERVATION TABLE:

	Theoretical	Experimental	Deviation
f_r			
Q			
f_1			
f_2			

Frequency	V_R
f_r=	
f_1=	
f_2=	
1kHz	
5kHz	
8kHz	
12kHz	
20kHz	
30kHz	
50kHz	
100kHz	

CALCULATIONS:

A large, empty rectangular box with a black border, intended for the student to perform calculations. The box is centered on the page and occupies most of the vertical space below the header.

Q-1) What is electrical resonance and explain its significance?

Q-2) Discuss one practical application of series resonance circuit?



Course Code and Title: _____

Laboratory Session: No. _____ Date: _____

Psychomotor Domain Assessment Rubric-Level P3					
Skill Sets	Extent of Achievement				
	0	1	2	3	4
Equipment Identification Sensory skill to identify equipment and/or its component for a lab work.	Not able to identify the equipment.	--	--	--	Able to identify equipment as well as its components.
Equipment Use Sensory skills to describe the use of the equipment for the lab work.	Never describes the use of equipment.	Rarely able to describe the use of equipment.	Occasionally describe the use of equipment.	Often able to describe the use of equipment.	Frequently able to describe the use of equipment.
Procedural Skills Displays skills to act upon sequence of steps in lab work.	Not able to either learn or perform lab work procedure.	Able to slightly understand lab work procedure and perform lab work.	Able to somewhat understand lab work procedure and perform lab work.	Able to moderately understand lab work procedure and perform lab work.	Able to fully understand lab work procedure and perform lab work.
Response Ability to imitate the lab work on his/her own.	Not able to imitate the lab work.	Able to slightly imitate the lab work.	Able to somewhat imitate the lab work.	Able to moderately imitate the lab work.	Able to fully imitate the lab work.
Observation's Use Displays skills to perform related mathematical calculations using the observations from lab work.	Not able to use lab work observations into mathematical calculations.	Able to slightly use lab work observations into mathematical calculations.	Able to somewhat use lab work observations into mathematical calculations.	Able to moderately use lab work observations into mathematical calculations.	Able to fully use lab work observations into mathematical calculations.
Safety Adherence Adherence to safety procedures.	Doesn't adhere to safety procedures.	Slightly adheres to safety procedures.	Somewhat adheres to safety procedures.	Moderately adheres to safety procedures.	Fully adheres to safety procedures.
Equipment Handling Equipment care during the use.	Doesn't handle equipment with required care.	Rarely handles equipment with required care.	Occasionally handles equipment with required care.	Often handles equipment with required care.	Handles equipment with required care.
Group Work Contributes in a group-based lab work.	Never participates.	Rarely participates.	Occasionally participates and contributes.	Often participates and contributes.	Frequently participates and contributes.

Lab Session 05

OBJECT:

- To understand the importance of test/switching functions.
- Design and test the performance of integrator circuits using Op-amp.

EQUIPMENT REQUIRED:

1. Signal generator
2. Resistors (1kΩ, 10kΩ, 100kΩ)
3. Capacitor (0.1μF, 0.039μF, 0.01μF, 0.03μF)
4. Oscilloscope
5. Op-amp (IC741)
6. Breadboard
7. Dual power supply
8. Connecting wires

THEROTICAL DESCRIPTION:

Integrator:

In an integrator circuit, the output voltage is integral of the input signal. The output voltage of an integrator is given by

$$V_0 = -\frac{1}{R_1 C_f} \int_0^t V_i dt$$

At low frequencies the gain becomes infinite, so the capacitor is fully charged and behaves like an open circuit. The gain of an integrator at low frequency can be limited by connecting a resistor in shunt with capacitor.

IC 741 Operational Amplifier

The IC 741 operational amplifier looks like a small chip. The main function of this IC is to do mathematical operations in various circuits. The pin configuration is shown below. It comprises of eight pins where the function of each pin is discussed below.

- Pin-1 is Offset null.
- Pin-2 is Inverting (-) i/p terminal.
- Pin-3 is a non-inverting (+) i/p terminal.
- Pin-4 is -Ve voltage supply (VCC)
- Pin-5 is offset null.
- Pin-6 is the o/p voltage.
- Pin-7 is +ve voltage supply (+VCC)
- Pin-8 is not connected.

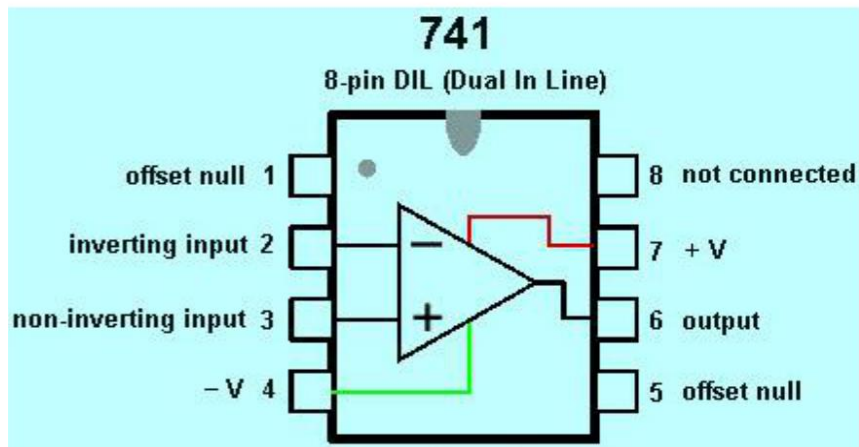

CIRCUIT DIAGRAM:

INTEGRATOR

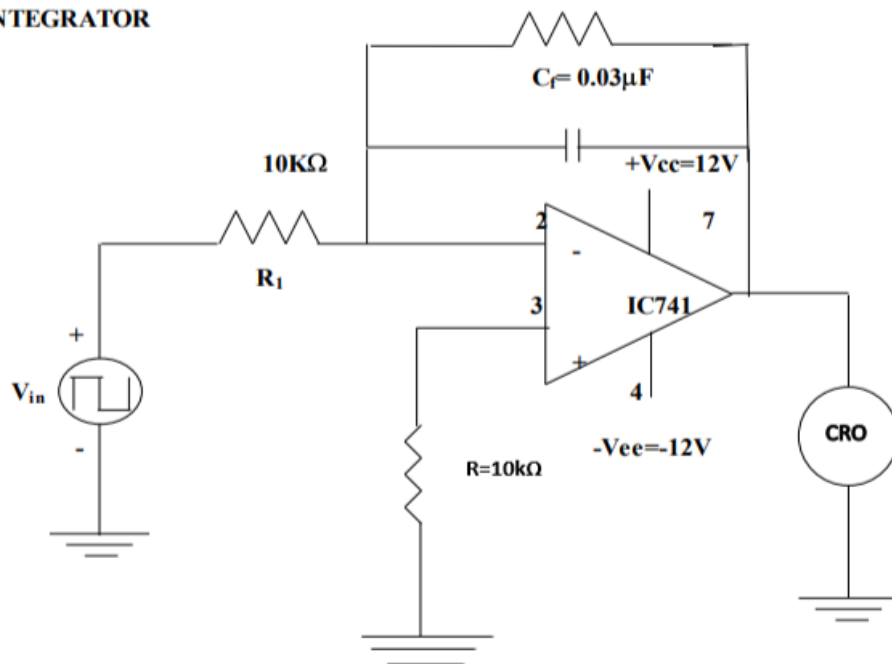

PROCEDURE:

1. Connections are made as per the circuit diagram.
2. Apply the square or sine input signal at **4kHz** frequency using AFO (Analog or digital function generator).
3. Note the corresponding output waveforms and plot the graph.

OBSERVATIONS:

Waveform:





Course Code and Title: _____

Laboratory Session: No. _____ Date: _____

Psychomotor Domain Assessment Rubric-Level P3					
Skill Sets	Extent of Achievement				
	0	1	2	3	4
Equipment Identification Sensory skill to identify equipment and/or its component for a lab work.	Not able to identify the equipment.	--	--	--	Able to identify equipment as well as its components.
Equipment Use Sensory skills to describe the use of the equipment for the lab work.	Never describes the use of equipment.	Rarely able to describe the use of equipment.	Occasionally describe the use of equipment.	Often able to describe the use of equipment.	Frequently able to describe the use of equipment.
Procedural Skills Displays skills to act upon sequence of steps in lab work.	Not able to either learn or perform lab work procedure.	Able to slightly understand lab work procedure and perform lab work.	Able to somewhat understand lab work procedure and perform lab work.	Able to moderately understand lab work procedure and perform lab work.	Able to fully understand lab work procedure and perform lab work.
Response Ability to imitate the lab work on his/her own.	Not able to imitate the lab work.	Able to slightly imitate the lab work.	Able to somewhat imitate the lab work.	Able to moderately imitate the lab work.	Able to fully imitate the lab work.
Observation's Use Displays skills to perform related mathematical calculations using the observations from lab work.	Not able to use lab work observations into mathematical calculations.	Able to slightly use lab work observations into mathematical calculations.	Able to somewhat use lab work observations into mathematical calculations.	Able to moderately use lab work observations into mathematical calculations.	Able to fully use lab work observations into mathematical calculations.
Safety Adherence Adherence to safety procedures.	Doesn't adhere to safety procedures.	Slightly adheres to safety procedures.	Somewhat adheres to safety procedures.	Moderately adheres to safety procedures.	Fully adheres to safety procedures.
Equipment Handling Equipment care during the use.	Doesn't handle equipment with required care.	Rarely handles equipment with required care.	Occasionally handles equipment with required care.	Often handles equipment with required care.	Handles equipment with required care.
Group Work Contributes in a group-based lab work.	Never participates.	Rarely participates.	Occasionally participates and contributes.	Often participates and contributes.	Frequently participates and contributes.

Lab Session 06

OBJECT:

- To understand the importance of test/switching functions.
- Design and test the performance of differentiator circuits using Op-amp.

EQUIPMENT REQUIRED:

1. Signal generator
2. Resistors (1kΩ, 10kΩ, 100kΩ)
3. Capacitor (0.1μF, 0.039μF, 0.01μF, 0.03μF)
4. Oscilloscope
5. Op-amp (IC741)
6. Breadboard
7. Dual power supply
8. Connecting wires

THEROTICAL DESCRIPTION:

Differentiator:

In the differentiator circuit the output voltage is the differentiation of the input voltage. The output voltage of a differentiator is given by

$$V_0 = -R_f C_1 \frac{dV}{dt}$$

The input impedance of this circuit decreases with increase in frequency, thereby making the circuit sensitive to high frequency noise. At high frequencies circuit may become unstable.

IC 741 Operational Amplifier

The IC 741 operational amplifier looks like a small chip. The main function of this IC is to do mathematical operations in various circuits. The pin configuration is shown below. It comprises of eight pins where the function of each pin is discussed below.

- Pin-1 is Offset null.
- Pin-2 is Inverting (-) i/p terminal.
- Pin-3 is a non-inverting (+) i/p terminal.
- Pin-4 is -Ve voltage supply (VCC)
- Pin-5 is offset null.
- Pin-6 is the o/p voltage.
- Pin-7 is +ve voltage supply (+VCC)
- Pin-8 is not connected.

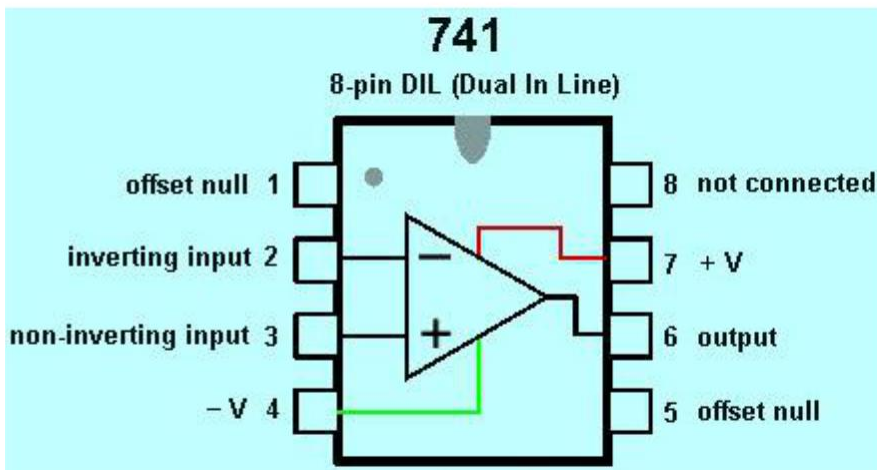

CIRCUIT DIAGRAM:

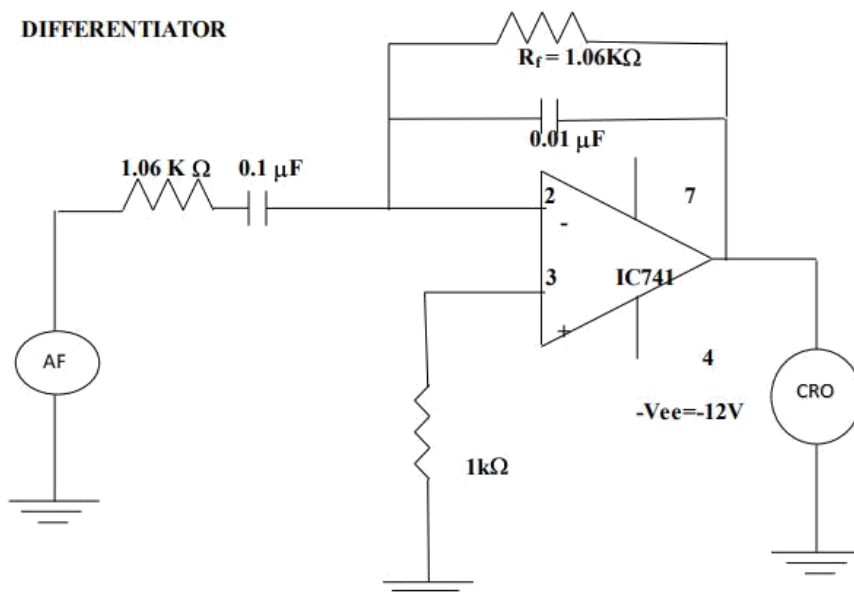

PROCEDURE:

4. Connections are made as per the circuit diagram.
5. Apply the square or sine input signal at **4kHz** frequency using AFO (Analog or digital function generator).
6. Note the corresponding output waveforms and plot the graph.

OBSERVATIONS:

Waveform:



Lab Session 07

OBJECT:

To investigate the behavior of Over Damping, Critical Damping & under Damping in RLC Circuit.

THEROTICAL DESCRIPTION:

L & C may have initial energy storage:

$$i_L(0) = I_0; v_C(0) = V_0$$

The second order differential equation for this circuit is:

$$\frac{d^2i}{dt^2} + \frac{R}{L} \frac{di}{dt} + \frac{i(t)}{LC} = 0$$

Depending on the values of R, L and C, the natural response will be either: Over damped, Critically Damped or Under damped. Let:

$$\alpha = \frac{R}{2L} = \text{neper frequency or exponential damping coefficient}$$

$$\omega_0 = \sqrt{\left(\frac{1}{LC}\right)} = \text{resonant (radian)frequency}$$

$$\omega_d = \sqrt{(\omega_0^2 - \alpha^2)} = \text{damped resonant frequency}$$

$$\varphi = \frac{\alpha}{\omega_0} = \text{damping ratio (dimensionless)}$$

(Note that all except the damping ratio have units of sec^{-1} .)

Hence:

$$s_1, s_2 = -\alpha \mp \sqrt{(\alpha^2 - \omega_0^2)} = \text{complex frequencies or natural frequencies}$$

Over damped Response: $\alpha > \omega_0$

s_1, s_2 are negative, real and distinct: $LC > 4L^2/R^2$

$$i_n(t) = A_1 e^{s_1 t} + A_2 e^{s_2 t} \quad i_n(t)$$

Critically Damped Response: $\alpha = \omega_0$

s_1, s_2 are negative, real and equal: $LC = 4L^2/R^2$

$$i_d(t) = e^{st} (A_1 + A_2 t)$$

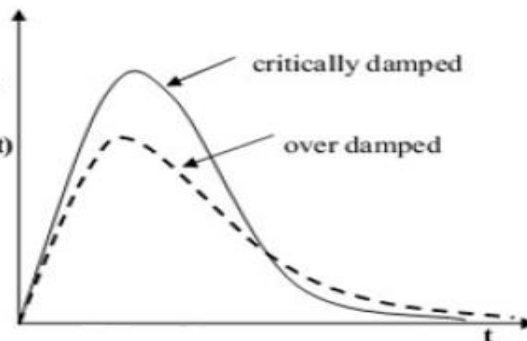

Under damped Response: $\alpha < \omega_0$

s_1, s_2 are distinct and complex: $LC < 4R^2C^2$

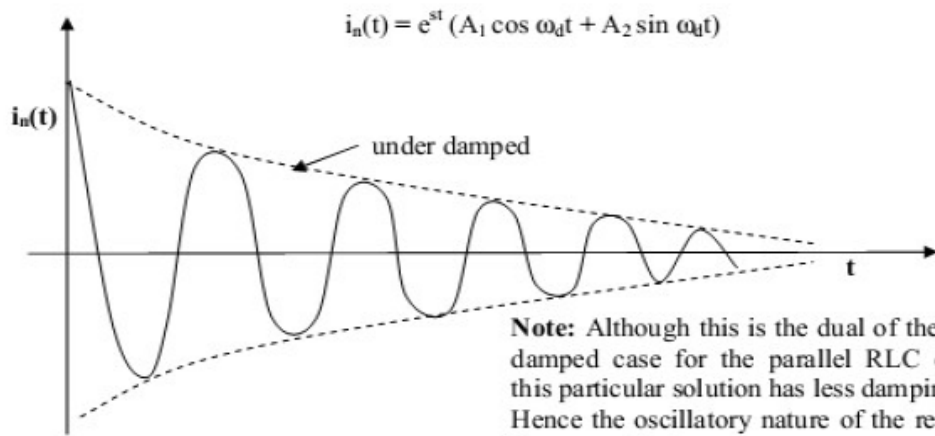

Note: Although this is the dual of the underdamped case for the parallel RLC circuit, this particular solution has less damping. Hence the oscillatory nature of the response is more evident. Also, the initial current was not zero here.

Notes:

- * t_m is the time at which the maximum value is reached.
- * t_s , the settling time, is the time at which the value is 1% of the maximum.

Circuit Diagram:

CIRCUIT NO 1(C1):

Design the circuit when $L= 1\text{mH}$, $R= 1\Omega$, $C=1\mu\text{F}$.

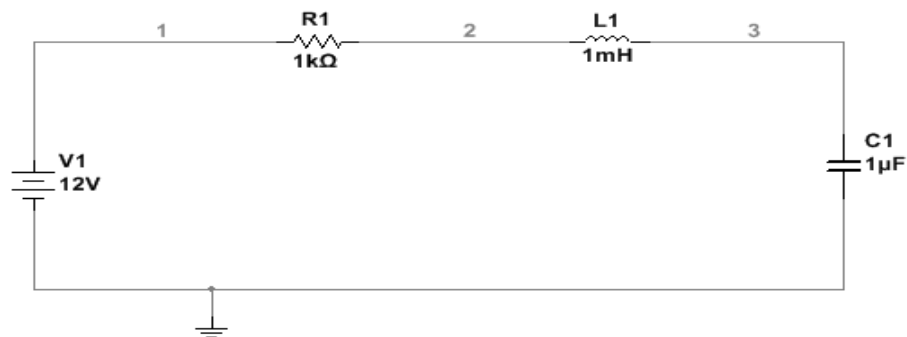

TASK 1:

Observe the response of RLC circuit when the switch changes its position after a certain time specified to the switch.

TASK 2:

Adjust the oscilloscope time base and voltage/div parameters for the observation.

OBSERVATIONS:

S. No.	R (Ω)	L (H)	C (F)	α	ω_0	DAMPING CASE	SETTING TIME t_s (s)	MAX. VOLTAGE V_{max} (V)

SIMULATION RESULT:

CONCLUSION:

Lab Session 08

OBJECT:

Use MATLAB to analyze types of power and RMS and peak values of current and voltages.

THEROTICAL DESCRIPTION:

Average Power:

The instantaneous electric power in an AC circuit is given by $P = VI$, but these quantities are continuously varying. Almost always the desired power in an AC circuit is the average power, which is given by

$$P_{avg} = VI\cos\phi$$

where ϕ is the phase angle between the current and the voltage and where V and I are understood to be the effective or rms values of the voltage and current. The term $\cos\phi$ is called the "power factor" for the circuit.

Power Factor:

In AC circuits, the power factor is the ratio of the real power that is used to do work and the apparent power that is supplied to the circuit. The power factor can get values in the range from 0 to 1. When all the power is reactive power with no real power (usually inductive load) - the power factor is 0. When all the power is real power with no reactive power (resistive load) - the power factor is 1.

RMS Value of Current or Voltage:

The RMS value is the effective value of a varying voltage or current. It is the equivalent steady DC (constant) value which gives the same effect. For example, a lamp connected to a 6V RMS AC supply will shine with the same brightness when connected to a steady 6V DC supply.

Task 1: Average power, Power factor and RMS value of voltage and current when

$$v(t)=10\cos(120\pi t+30)$$

$$i(t)=6\cos(120\pi t+60)$$

PROCEDURE

Source Code:

```
clear all; close all; clc;
Vm=10;%Maximum value of voltage
Im=6;
Vtheta=30*pi/180; %angle in radians
Itheta=60*pi/180;
p.f=cos(Vtheta-Itheta); %power factor & avg. power
P_avg=(Vm*Im/2)*cos(Vtheta-Itheta);
V_rms=Vm/sqrt(2);
I_rms=Im/sqrt(2);
fprintf('Average Power: %f \n',P_avg); %\n is for new line
fprintf('Power Factor: %f \n',p.f);
fprintf('RMS Voltage: %f \n',V_rms);
fprintf('RMS Current: %f \n',I_rms);
```

RESULT:

Average Power:
Power Factor:
RMS Voltage:
RMS Current:

In the above program if we add the following commands then we can draw the plot of average power.

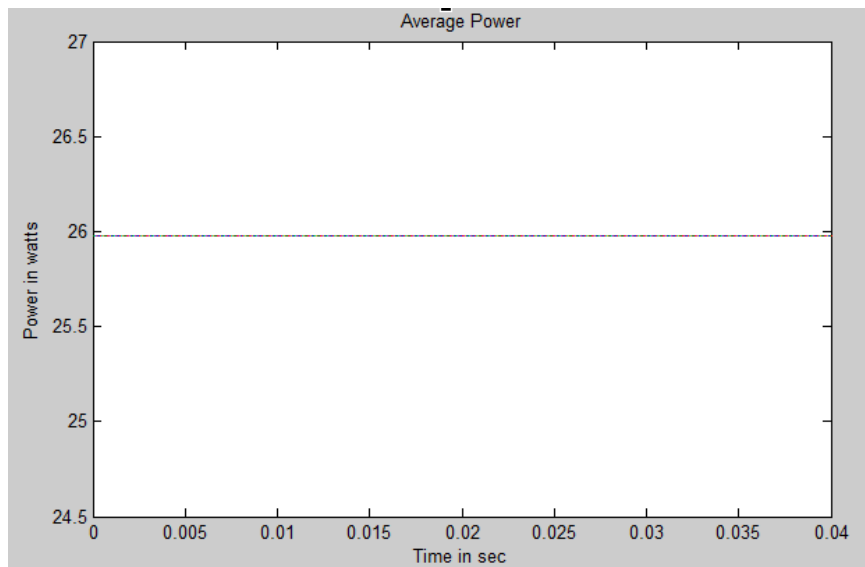

Task 2: Linear complex equations with unknown I_1 and I_2

$$(600+1250j).I1 + 100j.I2 = 25$$

$$100j.I1 + (60-150j).I2 = 0$$

Matrix form of above two equations

$$\begin{bmatrix} 600 + 1250j & 100j \\ 100j & 60 - 150j \end{bmatrix}$$

To solve this in MATLAB

Source Code:

```
clear all;
close all;
clc;
A=[600+1250j 100j;100j 60-150j];
B = [25;0];
I = inv(A)*B
MAGN=abs(I);
ANG=angle(I)*180/pi; %Converting angle from degrees into radians
fprintf('MAGNITUDE: %f \n',MAGN);
fprintf('ANGLE: %f \n',ANG);
```

RESULT:

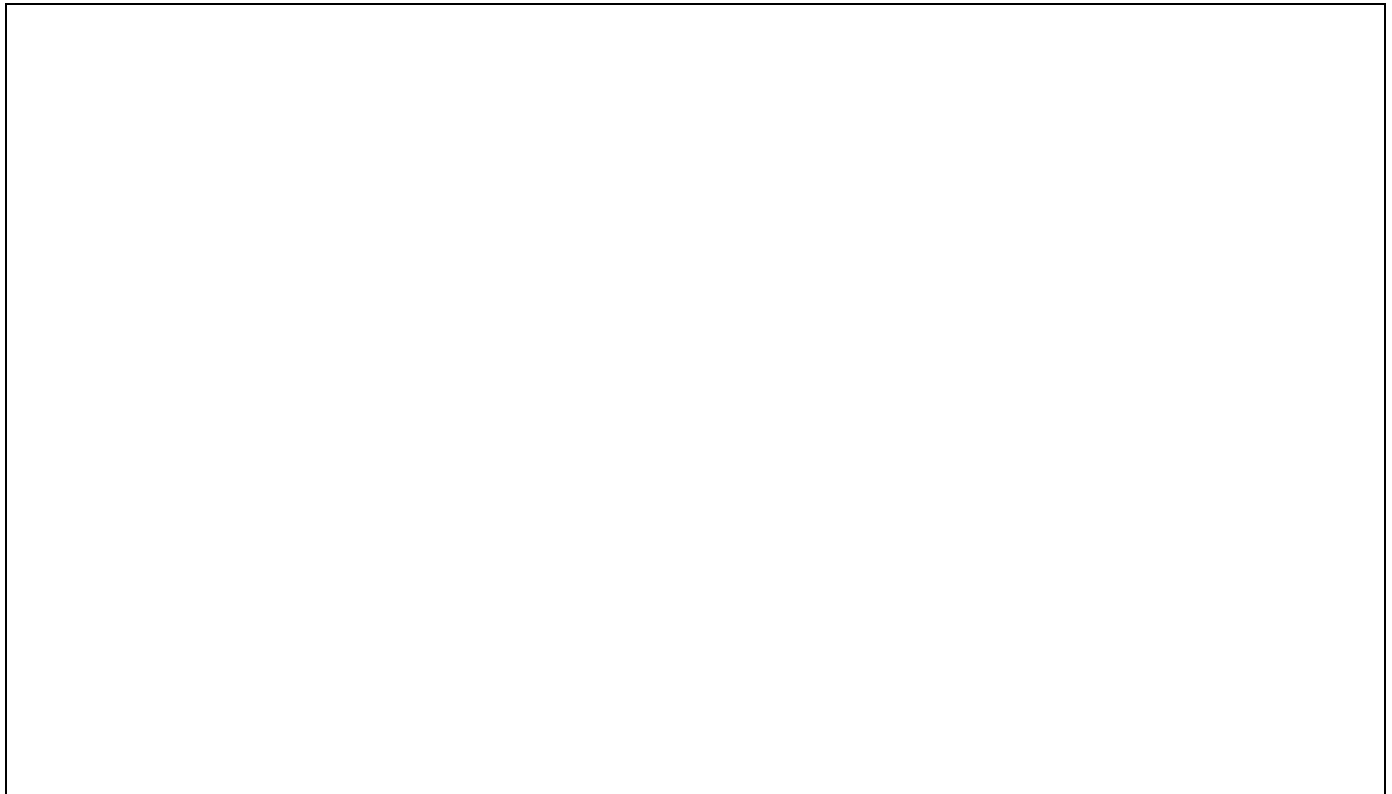

Now if we want to convert this phasor form of current in rectangular form then we have to use the following command

$$I_1 = \text{MAG} * \exp(\text{ANG} * j / 180);$$

The outcome will be

$$I_1 =$$

Lab Session 09

OPEN ENDED

OBJECT:

Use MATLAB and Simulink to plot waveforms of instantaneous voltage, current & Power for R, L& C and mixed & Load.

NED University of Engineering & Technology
Department of Electrical Engineering



Course Code:

Course Title:

Laboratory Session No.: _____

Date: _____

Psychomotor Domain Assessment Rubric for Laboratory (Level P3)					
Skill(s) to be assessed	Extent of Achievement				
	0	1	2	3	4
Software Initialisation and Configuration: Set up and <u>recognise</u> software initialisation and configuration steps	Completely unable to recognise initialisation and configuration	Able to recognise initialisation but could not configure	Able to recognise initialisation but configuration is erroneous	Able to recognise/perform initialisation and configuration with minimal errors	Able to recognise/perform initialisation and configuration with complete success
Software Menu Identification and Usage: Ability to <u>operate</u> software environment <u>under supervision</u> , using menus, shortcuts, instructions etc.	Unable to understand and use software menu	Little ability and understanding of software menu operation, makes many mistake	Moderate ability and understanding of software menu operation, makes lesser mistakes	Reasonable understanding of software menu operation, makes no major mistakes	Demonstrates command over software menu usage with frequent use of advance menu options
Modeling of given SLD/Network Diagram: Ability to <u>operate</u> software environment in order to create simulation model of given network parameters	Unable to operate software, could not create simulation model	Moderately able to operate software, could not create simulation model	Adequately able to operate software, simulation model contains errors	Adequately able to operate software, simulation model is error free	Demonstrates mastery over software, error free simulation model is created and simulation is started
Detecting and Removing Errors: <u>Detect</u> Errors/Exceptions and in simulation model and <u>manipulate</u> model to rectify the simulation	Unable to check and detect error messages and indications in software	Able to find error messages and indications in software but no understanding of detecting those errors and their types	Able to find error messages and indications in software as well as understanding of detecting some of those errors and their types	Able to find error messages in software as well as understanding of detecting all of those errors and their types	Able to find error messages in software along with the understanding to detect and rectify them

Psychomotor Domain Assessment Rubric for Laboratory (Level P3)

Skill(s) to be assessed	Extent of Achievement				
	0	1	2	3	4
<p>Graphical Visualisation and Comparison of Model/Network Parameters: <u>Manipulate</u> given model/simulation under supervision, in order to produce graphs/plots for measuring and comparing network parameters</p>	Unable to understand and utilise visualisation or plotting features	Ability to understand and utilise visualisation and plotting features with frequent errors	Ability to understand and utilise visualisation and plotting features successfully but unable to compare and analyse them	Ability to understand and utilise visualisation and plotting features successfully, partially able to compare and analyse them	Ability to understand and utilise visualisation and plotting features successfully, also able to draw conclusions after analysis
<p>Following step-by-step procedure to complete lab work: <u>Observe, imitate and operate</u> software to complete the provided sequence of steps</p>	Inability to recognise and perform given lab procedures	Able to recognise given lab procedures and perform them but could not follow the prescribed order of steps	Able to recognise given lab procedures and perform them by following prescribed order of steps, with frequent mistakes	Able to recognise given lab procedures and perform them by following prescribed order of steps, with occasional mistakes	Able to recognise given lab procedures and perform them by following prescribed order of steps, with no mistakes
<p>Recording Simulation Observations: <u>Observe and copy</u> prescribed or required simulation results in accordance with lab manual instructions</p>	Inability to recognise prescribed or required simulation measurements	Able to recognise prescribed or required simulation measurements but does not record according to given instructions	-	Able to recognise prescribed or required simulation measurements but records them incompletely	Able to recognise prescribed or required simulation measurements and records them completely, in tabular form
<p>Discussion and Conclusion: <u>Demonstrate</u> discussion capacity on the recorded observations and draw conclusions from it</p>	Complete inability to discuss recorded observations and draw conclusions	Slight ability to discuss recorded observations and draw conclusions	Moderate ability to discuss recorded observations and draw conclusions	Reasonable ability to discuss recorded observations and draw conclusions	Full ability to discuss recorded observations and draw conclusions

Lab Session 10

OBJECT:

To measure the Three Phase Power of Star connected load using Three Wattmeter methods.

EQUIPMENT REQUIRED:

- ✓ Three Watt-meters
- ✓ Ammeter
- ✓ Voltmeter
- ✓ Star Connected Load

THEROTICAL DESCRIPTION:

Power can be measured with the help of

1. Ammeter and voltmeter (In DC circuits)
2. Wattmeter
3. Energy meter

By Ammeter and Voltmeter:

Power in DC circuits or pure resistive circuit can be measured by measuring the voltage & current, then applying the formula $P=VI$.

By Energy Meter:

Power can be measured with the help of energy meter by measuring the speed of the meter disc with a watch, with the help of following formula:

$$P = \frac{N \times 60}{K} \text{ kW}$$

Where

N= actual r.p.m of meter disc

K= meter constant which is equal to disc revolutions per kW hr

By Wattmeter:

A wattmeter indicates the power in a circuit directly. Most commercial watt meters are of the dynamometer type with the two coils, the current and the voltage coil called C.C & P.C. Power in three phase circuit can be measured with the help of poly phase watt-meters which consist of one two or three single phase meters mounted on a common shaft.

Single Phase Power Measurement:

One wattmeter is used for single phase load or balanced three phase load, three and four wire

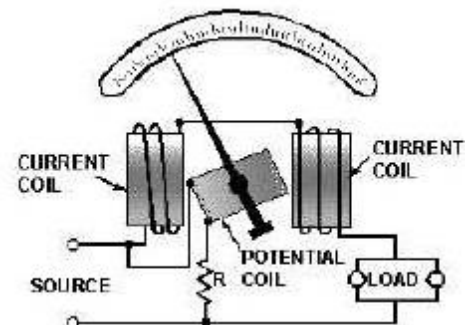

system. In three-phase, four wire system, p.c. coil is connected between phase to ground, while in three wire system, artificial ground is created.

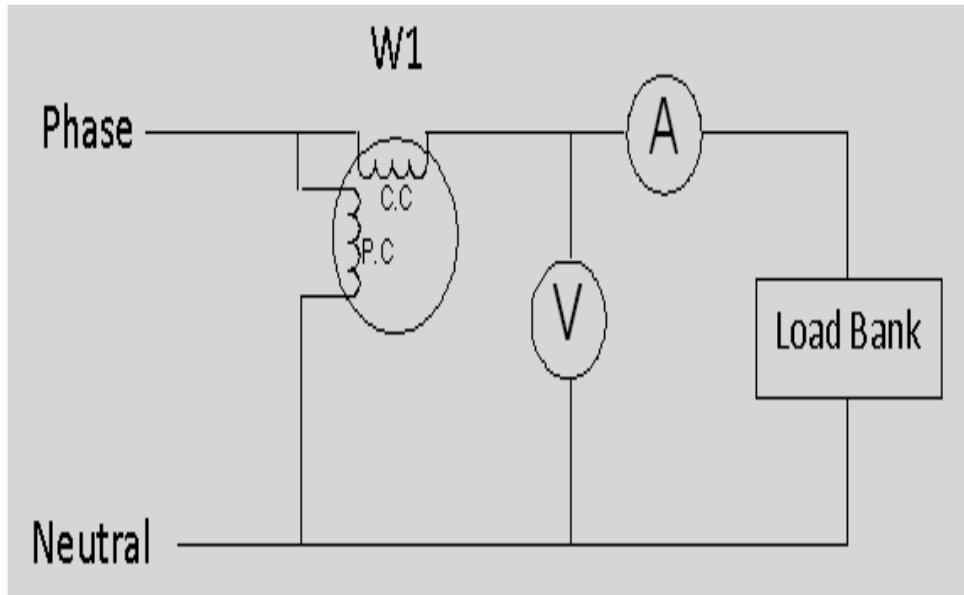

Figure: Single Wattmeter Method

PROCEDURE

Arrange the watt-meters as shown above.

OBSERVATION

Phase Voltage: _____

S. No.	Size of Load Bank (By Observation)	Measured Load (Using Wattmeter)	Current (A)	Voltage (V)
1	05x100W			
2	10x100W			

Three Phase Power Measurement Using Three Wattmeter Method:

Two watt-meters & three watt-meters are commonly used for three phase power measurement. In three watt-meter method, the potential coils are connected between phase and neutral. For three wire system, three watt-meter method can be used, for this artificial neutral is created.

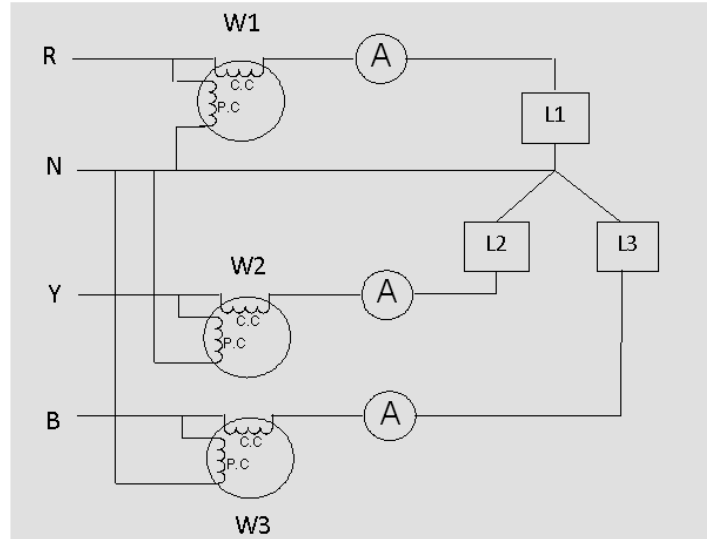

Figure: Three wattmeter method

PROCEDURE

Arrange the watt-meters as shown above.

OBSERVATION

Power of Star Connected Load: _____ W

Line to Line Voltage: _____ V

Line to Phase Voltage: _____ V

Using Three Wattmeter Method

S.No	Wattmeter Reading (W1)	Wattmeter Reading (W2)	Wattmeter Reading (W3)	W1+W2+W3	Current (A)
1					

RESULT:

Average Power:
Power Factor:

RMS Voltage:
RMS Current:

EXERCISE:

Here we are connecting phase with neutral without any load, doing this using a small wire in house could be very dangerous, then how it is possible here?

What do you understand by balance and unbalance load? In our case, is load balance or unbalance?

Suppose L1 is 70 W, ceiling fan, L2 is 100 W bulb, L3 is 350 W PC (Personal Computer), what amount of current will flow in the neutral?



Course Code and Title: _____

Laboratory Session: No. _____ Date: _____

Psychomotor Domain Assessment Rubric-Level P3					
Skill Sets	Extent of Achievement				
	0	1	2	3	4
Equipment Identification Sensory skill to identify equipment and/or its component for a lab work.	Not able to identify the equipment.	--	--	--	Able to identify equipment as well as its components.
Equipment Use Sensory skills to describe the use of the equipment for the lab work.	Never describes the use of equipment.	Rarely able to describe the use of equipment.	Occasionally describe the use of equipment.	Often able to describe the use of equipment.	Frequently able to describe the use of equipment.
Procedural Skills Displays skills to act upon sequence of steps in lab work.	Not able to either learn or perform lab work procedure.	Able to slightly understand lab work procedure and perform lab work.	Able to somewhat understand lab work procedure and perform lab work.	Able to moderately understand lab work procedure and perform lab work.	Able to fully understand lab work procedure and perform lab work.
Response Ability to imitate the lab work on his/her own.	Not able to imitate the lab work.	Able to slightly imitate the lab work.	Able to somewhat imitate the lab work.	Able to moderately imitate the lab work.	Able to fully imitate the lab work.
Observation's Use Displays skills to perform related mathematical calculations using the observations from lab work.	Not able to use lab work observations into mathematical calculations.	Able to slightly use lab work observations into mathematical calculations.	Able to somewhat use lab work observations into mathematical calculations.	Able to moderately use lab work observations into mathematical calculations.	Able to fully use lab work observations into mathematical calculations.
Safety Adherence Adherence to safety procedures.	Doesn't adhere to safety procedures.	Slightly adheres to safety procedures.	Somewhat adheres to safety procedures.	Moderately adheres to safety procedures.	Fully adheres to safety procedures.
Equipment Handling Equipment care during the use.	Doesn't handle equipment with required care.	Rarely handles equipment with required care.	Occasionally handles equipment with required care.	Often handles equipment with required care.	Handles equipment with required care.
Group Work Contributes in a group-based lab work.	Never participates.	Rarely participates.	Occasionally participates and contributes.	Often participates and contributes.	Frequently participates and contributes.

Lab Session 11

OBJECT:

To measure the Three Phase Power of Delta connected load using Two Wattmeter methods

EQUIPMENT REQUIRED:

- ✓ Three Watt-meters
- ✓ Ammeter
- ✓ Voltmeter
- ✓ Delta Connected Load

THEROTICAL DESCRIPTION:

Two Wattmeter Method:

In two watt-meter method, two watt meters are used & their potential coils are connected between phase to phase and current coil in series with the line. Two watt meters can be used to measure power of star and delta connected load, but here we are performing experiment on delta connected load only, same method can be applied for star connected load. Following formulas are used for calculating P, Q and p.f.

TWO WATTMETER CALCULATIONS

1) Real power

$$P = W_1 + W_2$$

2) Reactive power

$$Q = \sqrt{3} (W_2 - W_1)$$

3) Power Factor

$$\cos \theta = \frac{P}{\sqrt{P^2 + Q^2}}$$

$$\cos \theta = \sqrt{\frac{P^2}{P^2 + Q^2}}$$

$$\cos \theta = \sqrt{\frac{(W_1 + W_2)^2}{(W_1 + W_2)^2 + 3(W_2 - W_1)^2}}$$

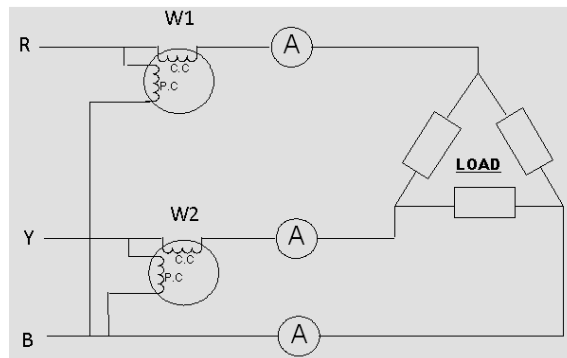

Figure: Two Wattmeter Method

PROCEDURE

Arrange the watt-meters according to the load (single phase or three-phase) and whether neutral available or not (as shown in the above figures).

OBSERVATION

Power of Delta Connected Load: 2 bulbs in series of W

Line to line Voltage: _____ V

Using Two Wattmeter Method

S.No	Type of Load	Wattmeter Reading (W1)	Wattmeter Reading (W2)	W1+W2	p.f.	Current (I _L)
1.	Three Phase Delta Connected Load					

RESULT:

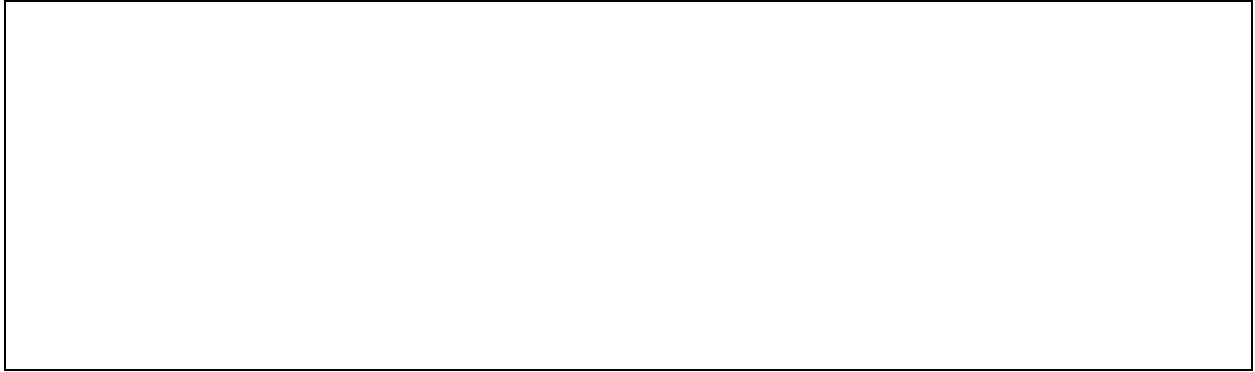

EXERCISE:

Here for each delta connected load we are connecting two bulbs in series, why?



Course Code and Title: _____

Laboratory Session: No. _____ Date: _____

Psychomotor Domain Assessment Rubric-Level P3					
Skill Sets	Extent of Achievement				
	0	1	2	3	4
Equipment Identification Sensory skill to identify equipment and/or its component for a lab work.	Not able to identify the equipment.	--	--	--	Able to identify equipment as well as its components.
Equipment Use Sensory skills to describe the use of the equipment for the lab work.	Never describes the use of equipment.	Rarely able to describe the use of equipment.	Occasionally describe the use of equipment.	Often able to describe the use of equipment.	Frequently able to describe the use of equipment.
Procedural Skills Displays skills to act upon sequence of steps in lab work.	Not able to either learn or perform lab work procedure.	Able to slightly understand lab work procedure and perform lab work.	Able to somewhat understand lab work procedure and perform lab work.	Able to moderately understand lab work procedure and perform lab work.	Able to fully understand lab work procedure and perform lab work.
Response Ability to imitate the lab work on his/her own.	Not able to imitate the lab work.	Able to slightly imitate the lab work.	Able to somewhat imitate the lab work.	Able to moderately imitate the lab work.	Able to fully imitate the lab work.
Observation's Use Displays skills to perform related mathematical calculations using the observations from lab work.	Not able to use lab work observations into mathematical calculations.	Able to slightly use lab work observations into mathematical calculations.	Able to somewhat use lab work observations into mathematical calculations.	Able to moderately use lab work observations into mathematical calculations.	Able to fully use lab work observations into mathematical calculations.
Safety Adherence Adherence to safety procedures.	Doesn't adhere to safety procedures.	Slightly adheres to safety procedures.	Somewhat adheres to safety procedures.	Moderately adheres to safety procedures.	Fully adheres to safety procedures.
Equipment Handling Equipment care during the use.	Doesn't handle equipment with required care.	Rarely handles equipment with required care.	Occasionally handles equipment with required care.	Often handles equipment with required care.	Handles equipment with required care.
Group Work Contributes in a group-based lab work.	Never participates.	Rarely participates.	Occasionally participates and contributes.	Often participates and contributes.	Frequently participates and contributes.

Lab Session 12

OBJECT:

To determine the turns ratio of a transformer, also determine the polarity of transformer windings for their parallel operation

EQUIPMENT REQUIRED:

- ✓ Two Single Phase Transformers (T1 & T2)
- ✓ Ammeter
- ✓ Voltmeter

THEROTICAL DESCRIPTION:

Turns Ratio:

Transformers provide a simple means of changing an alternating voltage from one value to another, keeping the apparent power S constant.

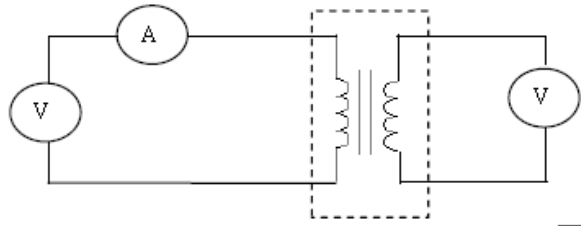

Figure 1. Finding the

turns ratio

For a given transformer, the turns ratio can be find out using the relation.

$$\frac{V_P}{V_S} = \frac{N_P}{N_S} = \frac{I_S}{I_P} = a$$

Transformer Polarity:

When we speak "the polarity" of transformer windings, we are identifying all of the terminals that are the same polarity at any instant of time. "Polarity marks" are employed to identify these terminals. These marks may be black dots, crosses, numerals, letters, or any other convenient means of showing which terminal are of the same polarity. In our case, we use black dots. The black dots, as shown in the figure, indicate that for a given instant in time: *when 1 is positive with respect to 2, then 3 is positive with respect to 4.*

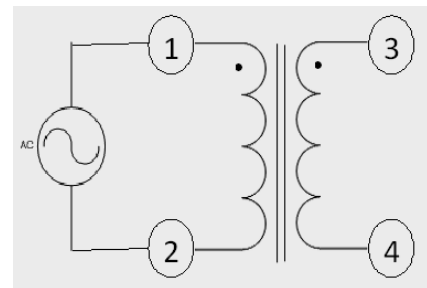

The identification of polarity becomes essential when we operate the two transformers in parallel. Otherwise *if terminals of unlike polarity connected to the same line, the two secondary windings would be short circuited on each other with a resulting excessive current flow.*

Suppose we have two transformers T1 & T2, having terminals H1, H2 (HV) & X1, X2(LV) as shown in figure 2. The transformers in fig 2 are so marked that if the H1 s are connected to one primary line and the H2 s to the other primary line then the X1 s should be connected to the same secondary line and X2 s to the remaining secondary line.

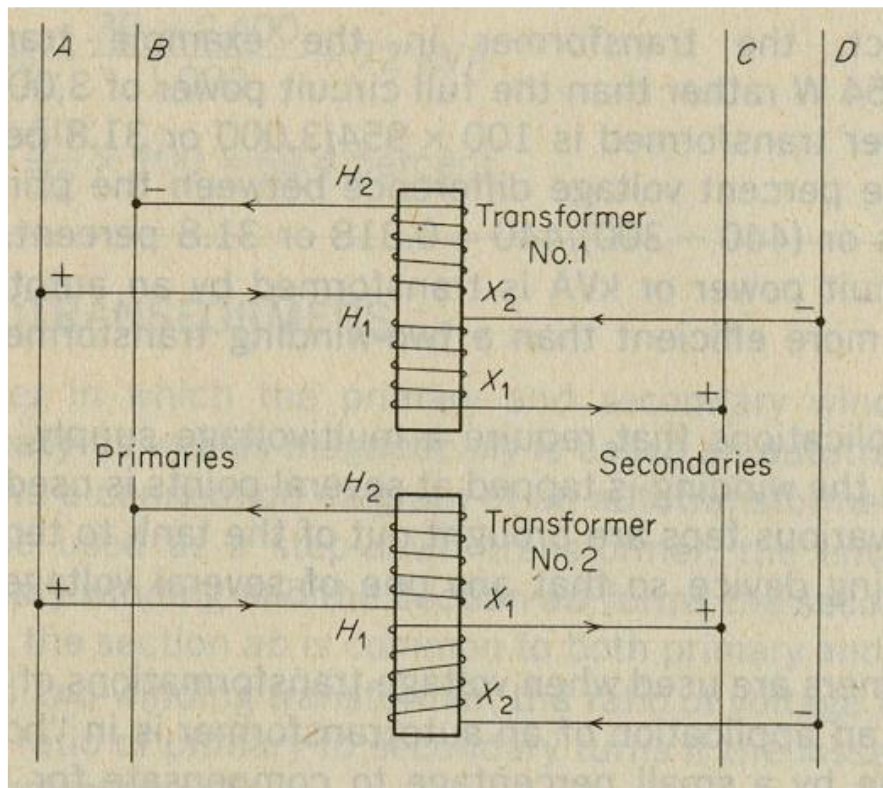

Figure 2: Two transformers connected for parallel operation

If the transformer terminals are arranged as shown in fig 3a, the transformer is said to have additive polarity and if arranged as shown in fig 3b, the transformer is said to have subtractive polarity.

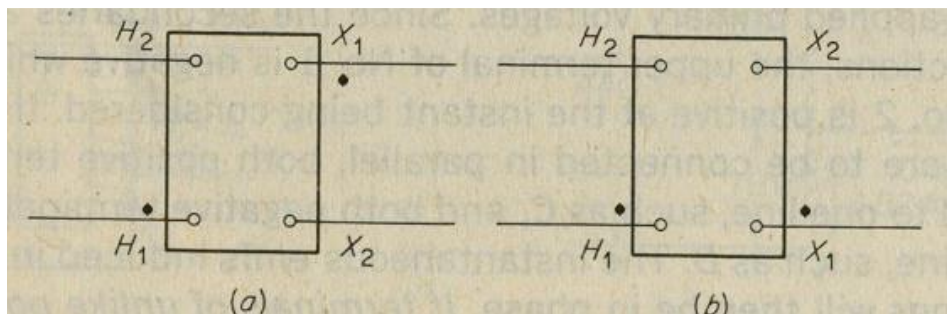

Figure 3: Standard polarity markings of transformers (a) additive polarity (b) subtractive polarity

If the polarity of the transformer is not known, it may be determined by the test connections shown in figure 4. Here low voltage side terminals may be temporary marked as X_A and X_B as shown in figure.

Adjacent terminals are then connected and a voltmeter is connected across the other two terminals H_1 and X_B . Any convenient voltage is then applied to the high voltage winding of the transformer. If the voltmeter reads less than the value of the applied voltage, the polarity is subtractive and the terminals X_A & X_B may be marked as the X_2 and X_1 terminals, respectively.

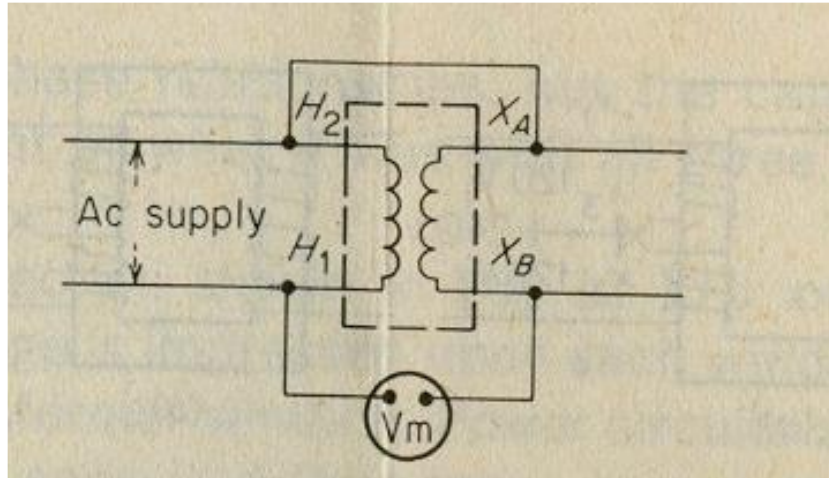

Figure 4: Connection for checking the polarity of a transformer

PROCEDURE

Finding out Turns Ratio:

1. Apply 220V AC to the primary of transformer T1 through autotransformer
2. Now measure V_s using voltmeter.
3. Now calculate turns ratio a and tabulate in observation column.
4. Repeat for transformer T2.

Finding out Turns Ratio:

1. Make connections according to the given circuit fig 4 for T1 and find out the polarity.
2. Make connections according to the given circuit fig 4 for T2 and find out the polarity.
3. Now connect the two transformers according to the figure 2.

OBSERVATION

The turns ratio for transformer T1 is found to be $a =$ _____

The turns ratio for transformer T2 is found to be $a =$ _____

Mark the dot (\cdot) on the given two transformers, also connects the two with the buses using pencil.

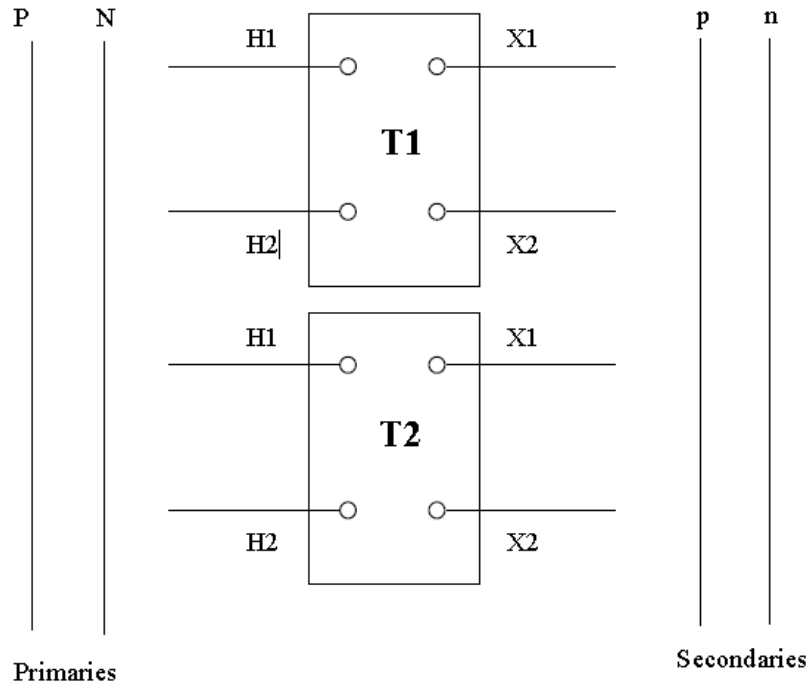

RESULT:

A large empty rectangular box intended for the student to write the result of the experiment.

EXERCISE:

Why must the transformer polarities be known when transformers are being connected for parallel operation?

In figure 1, there is no load connected except voltmeter, but some amount of current is flowing in the primary, why? What this current is called?

Lab Session 13

OBJECT:

To investigate ABCD Transmission Parameters for Two Port Network.

THEROTICAL DESCRIPTION:

ABCD parameters are widely used in analysis of power transmission engineering where they are termed as “Circuit Parameters”. ABCD parameters are also known as “Transmission Parameters”. In these parameters, the voltage & current at the sending end terminals can be expressed in terms of voltage & current at the receiving end. Thus,

$$V_1 = AV_2 + B(-I_2)$$

$$I_1 = CV_2 + D(-I_2)$$

Here “A” is called reverse voltage ratio, “B” is called transfer impedance “C” is called transfer admittance & “D” is called reverse current ratio.

CIRCUIT DIAGRAM:

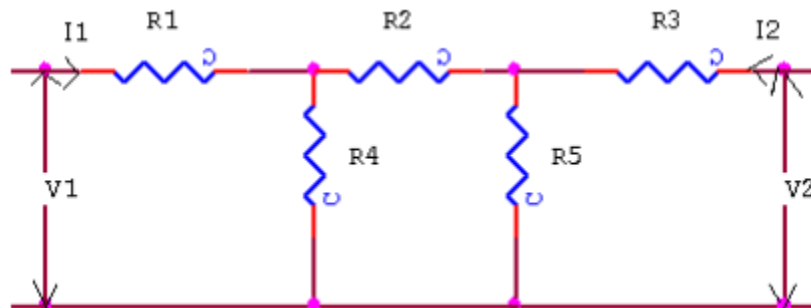

PROCEDURE:

- Connect the circuit as shown in fig. & switch ‘ON’ the experimental board.
- First open the O/P terminal & supply 5V to I/P terminal. Measure O/P voltage & I/P current
- Secondly, short the O/P terminal & supply 5V to I/P terminal. Measure I/P & O/P current using multi-meter.
- Calculate the A, B, C, & D parameters using the Eq. (1) & (2).
- Switch ‘off’ the supply after taking the readings.

OBSERVATIONS:

S.No	When O/P is open ckt			When O/P is short ckt		
	V ₁	V ₂	I ₁	V ₁	I ₂	I ₁

CIRCUIT SIMULATIONS:

CALCULATIONS:

CONCLUSION:

Cover Page for Each PBL/OEL

Course Code:	EE-127
Course Name:	Circuit Analysis
Semester:	Spring
Year:	20__
Section:	
Batch:	
Lab Instructor name:	
Submission deadline:	

PBL or OEL Statement:

A three phase line has an impedance of $2+j4$ ohms. The line feeds two balanced three phase loads that are connected in parallel. The first load is Y-connected and has an impedance of $30+j40$ ohms per phase. The second load is Delta connected and has an impedance of $60-j45$ ohms per phase. The line energized at the sending end from a three phase balanced supply of line voltage 207.85 V. Taking the phase voltage V_a as reference, determine (i) The current, real power and reactive power drawn from the supply (ii) The line voltage at the combined loads (iii) The current per phase in each load (iv) The total real and reactive powers in each load and the line.

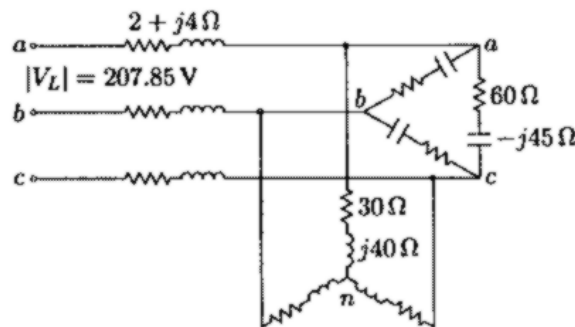

Deliverables:

Write the report containing all calculations by hand and simulation on Matlab/Simulink. Include all code and waveforms

Methodology:

1. Transform the delta connected into wye connected load.
2. Find phase voltage
3. Make a single phase equivalent circuit.
4. Find total impedance, phase current and 3 phase power supplied.
5. Find Phase voltage and line voltage at load
6. Find current per phase in both loads
7. Find three phase power by each load, line and verify that power delivered is power supplied.

Guidelines: The report should be maximum 5 pages long which should include figures, calculations, simulation results and waveforms of line and phase currents and voltages. Attach these two pages on top of the report.

Rubrics: Standard software rubrics as defined for EE-127

NED University of Engineering & Technology
Department of Electrical Engineering



Course Code: _____

Course Title: _____

Laboratory Session No.: _____

Date: _____

Psychomotor Domain Assessment Rubric for Laboratory (Level P3)					
Skill(s) to be assessed	Extent of Achievement				
	0	1	2	3	4
Software Initialisation and Configuration: Set up and <u>recognise</u> software initialisation and configuration steps	Completely unable to recognise initialisation and configuration	Able to recognise initialisation but could not configure	Able to recognise initialisation but configuration is erroneous	Able to recognise/perform initialisation and configuration with minimal errors	Able to recognise/perform initialisation and configuration with complete success
Software Menu Identification and Usage: Ability to <u>operate</u> software environment <u>under supervision</u> , using menus, shortcuts, instructions etc.	Unable to understand and use software menu	Little ability and understanding of software menu operation, makes many mistake	Moderate ability and understanding of software menu operation, makes lesser mistakes	Reasonable understanding of software menu operation, makes no major mistakes	Demonstrates command over software menu usage with frequent use of advance menu options
Modeling of given SLD/Network Diagram: Ability to <u>operate</u> software environment in order to create simulation model of given network parameters	Unable to operate software, could not create simulation model	Moderately able to operate software, could not create simulation model	Adequately able to operate software, simulation model contains errors	Adequately able to operate software, simulation model is error free	Demonstrates mastery over software, error free simulation model is created and simulation is started
Detecting and Removing Errors: <u>Detect</u> Errors/Exceptions and in simulation model and <u>manipulate</u> model to rectify the simulation	Unable to check and detect error messages and indications in software	Able to find error messages and indications in software but no understanding of detecting those errors and their types	Able to find error messages and indications in software as well as understanding of detecting some of those errors and their types	Able to find error messages in software as well as understanding of detecting all of those errors and their types	Able to find error messages in software along with the understanding to detect and rectify them

Psychomotor Domain Assessment Rubric for Laboratory (Level P3)

Skill(s) to be assessed	Extent of Achievement				
	0	1	2	3	4
<p>Graphical Visualisation and Comparison of Model/Network Parameters: <u>Manipulate</u> given model/simulation under supervision, in order to produce graphs/plots for measuring and comparing network parameters</p>	Unable to understand and utilise visualisation or plotting features	Ability to understand and utilise visualisation and plotting features with frequent errors	Ability to understand and utilise visualisation and plotting features successfully but unable to compare and analyse them	Ability to understand and utilise visualisation and plotting features successfully, partially able to compare and analyse them	Ability to understand and utilise visualisation and plotting features successfully, also able to draw conclusions after analysis
<p>Following step-by-step procedure to complete lab work: <u>Observe, imitate and operate</u> software to complete the provided sequence of steps</p>	Inability to recognise and perform given lab procedures	Able to recognise given lab procedures and perform them but could not follow the prescribed order of steps	Able to recognise given lab procedures and perform them by following prescribed order of steps, with frequent mistakes	Able to recognise given lab procedures and perform them by following prescribed order of steps, with occasional mistakes	Able to recognise given lab procedures and perform them by following prescribed order of steps, with no mistakes
<p>Recording Simulation Observations: <u>Observe and copy</u> prescribed or required simulation results in accordance with lab manual instructions</p>	Inability to recognise prescribed or required simulation measurements	Able to recognise prescribed or required simulation measurements but does not record according to given instructions	-	Able to recognise prescribed or required simulation measurements but records them incompletely	Able to recognise prescribed or required simulation measurements and records them completely, in tabular form
<p>Discussion and Conclusion: <u>Demonstrate</u> discussion capacity on the recorded observations and draw conclusions from it</p>	Complete inability to discuss recorded observations and draw conclusions	Slight ability to discuss recorded observations and draw conclusions	Moderate ability to discuss recorded observations and draw conclusions	Reasonable ability to discuss recorded observations and draw conclusions	Full ability to discuss recorded observations and draw conclusions